

D-c current transducer under test. Device performs same function as a d-c shunt, however the metering circuit is electrically isolated, reducing hazard and amount of insulation required. Power dissipation is generally much less than in a comparable shunt.

How Magnetic Amplifiers Operate

G. H. STEARLEY
 Engineering Department, Small Motor Division
 Westinghouse Electric Corporation

IMPROVEMENTS IN MATERIALS, in design, or in basic application concepts often result in the rediscovery of a relatively old device, and in its widespread use in new equipment. Such is the case with the magnetic amplifier, an electrical control tool that in many instances can outperform electronic amplifiers, and can do so without "kid glove" treatment. Present applications

are to the control circuits of automatic pilots, fire control apparatus, voltage and frequency regulators, winding reels, adjustable speed motors, battery chargers, and many types of industrial equipment. Basically, a magnetic amplifier consists of a saturable core reactor and a fixed plate rectifier. If a low voltage is applied to a simple iron-core reactor,

the current through the reactor builds up until the induced back emf is high enough to establish steady state conditions, permitting the flow of only a small exciting current. If the voltage, and hence the magnetizing force, is gradually increased, the flux density will increase. By definition, the permeability μ of the core is at any point equal to the slope of the *B-H* curve

at that given point. Therefore, the permeability is maximum at the point of inflection on the magnetization curve, and approaches zero in the region of absolute core saturation.

Examination of the fundamental equation,

$$L = KN^2\mu \frac{A}{l} \quad (1)$$

wherein A and l are core dimensions (cross sectional area and length), N is the number of turns, and K is a constant, shows that the inductance, L , and therefore the impedance, Z , of an inductor is directly proportional to the permeability, μ . Thus, any control scheme which varies μ is in fact varying the amount of current that is circulated through the inductor at a fixed applied voltage.

This idea is represented graphically in Fig. 1. If "a" is chosen as the operating point, an alternating flux, ϕ_1 , is set up, and the back emf,

$$e_1 = N \frac{d\phi_1}{dt}$$

is quite large. But if the operating point is moved to "b", near the saturation region, ϕ_2 is small, hence the back emf,

$$e_2 = N \frac{d\phi_2}{dt}$$

is small, and a high value of current can flow.

Although special core materials have been developed to give nearly rectangular hysteresis loops, a saturable reactor, as used in the simplest form of magnetic amplifiers, operates in a manner similar to that depicted in Fig. 1. The application of a d-c voltage to individual windings on the core serves to translate the operating point along the magnetization curve, and thus regulate the flow of power current to the load.

A simplified magnetic-amplifier circuit is shown in Fig. 2, along with oscillograms of load-voltage corresponding to different operating points along the magnetization curve. In this circuit, a high impedance is placed in series with the control circuit to minimize the flow of a-c currents set up by transformer action. The rectifier in series with the load prevents demagnetization of the core on the negative one-half of each power cycle. If operation occurs about point a , the change in flux caused by the alternating supply voltage would not be greater than the flux change, $a-c$, required to saturate the core; therefore, almost all of the supply voltage, E_{1c} , would appear across the reactor. The load voltage, E_L , would be negligible. At point b on the curve, the available flux change would be greater than $b-c$, the amount

required for saturation. In this case the core would be saturated during the latter part of the cycle and some current would pass through the load, developing a small voltage, E_L . At other points along the curve, saturation would occur earlier in the cycle, and a correspondingly greater load voltage would be developed. Operation at point r would result in nearly all of

the supply voltage being absorbed by the load. In any case, the voltage on the negative one-half of each cycle would appear across the rectifier, if the rectifier permitted no reverse-current leakage.

A schematic diagram of one type of self-saturating magnetic amplifier is shown in Fig. 3. The a-c power windings are placed on the outer legs of the

- Ruggedness and ability to withstand severe shock and vibration. Magnetic amplifiers also require no warm-up period, contain no moving parts, operate at low cost, require a minimum of maintenance, and have long life.

- Input circuits can be completely isolated, galvanically, from the output circuit. Multiple input circuits can be used to "mix" the separate signals so the amplifier responds to the composite or algebraic sum of the signals.

- Little energy dissipation. (This is in direct contrast to vacuum tubes, the internal impedance of which is resistive instead of inductive.) Can be designed to match the impedance of both the load and the signal source. No matching transformers are required.

- Output is nearly independent of fluctuations in a-c supply voltage. Amplifiers have been designed wherein a thirty percent change in a-c voltage caused no more than one and one-half percent change in output current.

- No practical size limitation. Ratings up to 50,000 KVA, and power gains up to 100,000 are feasible in multiple stage units.

Limitations of Magnetic Amplifiers

- Because of their iron-core construction, saturable-reactor applications are limited to the lower frequency ranges. While this limits some radio and radar applications, it has no practical effect on most industrial uses.

- Speed-of-response is low, especially at lower frequencies. This time delay may cause "hunting" in some types of control circuits. The use of a multiple number of control windings further reduces speed-of-response.

- Unless push-pull circuits are used, "zero-signal" correction can be achieved only by additional compensating reactors or by the addition of extra windings to the existing reactor. Obviously, this increases the cost of the amplifier.

- Magnetic amplifiers often become unstable when used to supply highly inductive loads. A commutating rectifier across the load may be necessary to short-circuit the current flow initiated by the collapse of the magnetic field which surrounds the inductive loads.

- Amplification is low for small signal inputs, unless permanent-magnet biasing or some equivalent scheme is used.

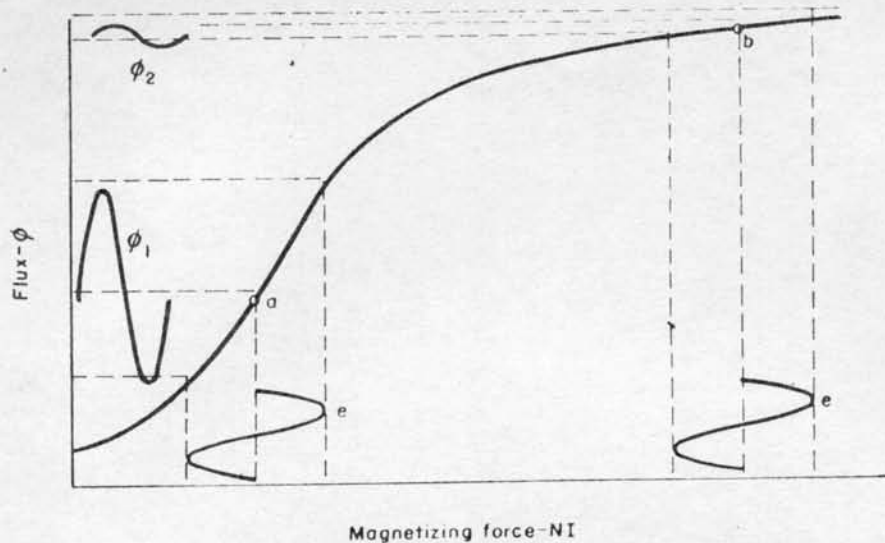

Fig. 1—Effect of saturation on an iron core reactor. If *a* is the operating point, the back emf is large and only a small amount of current can flow. The converse is true if *b* is the operating point. A saturable reactor as used in the simplest form of magnetic amplifiers operates in a similar manner to regulate current flow.

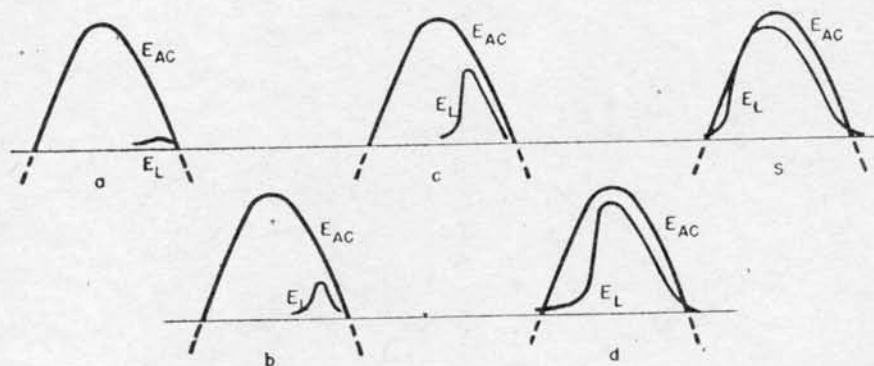
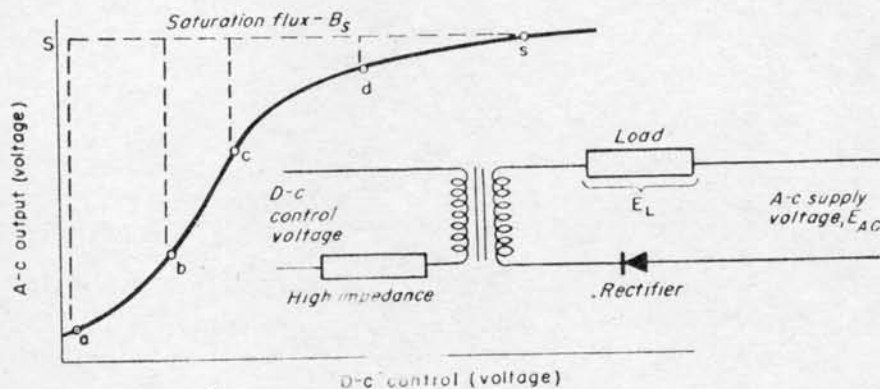

Fig. 2—Magnetization curve of a simple magnetic amplifier, and oscillograph traces of supply voltage relationships at points *a*, *b*, *c*, *d*, and *s* along the curve. The impedance in this circuit minimizes the flow of a-c current resulting from transformer action, and the rectifier prevents demagnetization on the negative half of the power cycle.

core. Dry-plate rectifiers are inserted in series with each a-c coil to prevent demagnetization of the core on the negative one-half of each cycle. The d-c control circuit is wound over the center leg. The unidirectional flux set up by the d-c winding passes through the center path of the core and divides

into the two outer legs. The total flux in the center leg is actually a pulsating unidirectional flux.

The magnetic amplifier circuit of Fig. 4 is similar to the three-coil circuit of Fig. 3, but it is designed to give a d-c output. The similarity between this circuit and a full-wave electronic-rec-

tifier circuit is evident from the circuit.

The gain or amplification factor of a simple magnetic amplifier can be greatly increased if self-excitation is used. Fig. 5 illustrates the use of feedback or self-excitation. In this circuit the a-c load current is rectified and passed through two windings, one on each saturable reactor. Although it has a pulsating characteristic, this rectified current which is "fed back" supplements the separate d-c control current in determining the position of the operating point on the saturation curve. The feed-back current may aid or oppose the separate d-c control current. In either case the degree of core saturation will depend on net flux, and the magnitude of the d-c signal required to produce a given change in load current will be relatively small. To indicate this graphically, reference is made to Fig. 6. The curve, XYZ, represents a typical plot of a-c output current as a function of total d-c control current, for a given core material and a given applied a-c voltage. The total d-c control current referred to would be the sum of feed-back current and signal current, along with bias current, if the latter were used. Assuming that the rectifier is perfect (that is, it has zero forward resistance and infinite backward resistance), the rectified feed-back current will be proportional to the a-c output current at every instant. Therefore, this relationship will be a straight line such as *OL*. The slope of the line will be determined by the magnitude of the feedback. If no signal current were applied, the total d-c control current would be comprised of the rectified feedback current only. Since the operating point would have to lie on both curve *XYZ* and line *OL*, it would be at point *J*, the intersection of the two. Thus *OM* would be the a-c load current that would flow. To increase the load current to a value *ON*, a signal current equal to *KP* only, would be required. Of the total d-c control current, *NP*, the amount *NK* would be furnished by self-excitation.

Unusual characteristics may be obtained by the application of a large amount of positive feedback. Consider the curve shown in Fig. 7. With no signal current, but with relative feedback proportional to the slope of the line, *OR*, operation would occur about point *P*, permitting a large a-c load current. If a signal current equal to *OA* were applied in opposition to the self-excitation current, the position of line, *OR*, would be translated to position *AC*, and the load current would be reduced. Then if the opposing signal current were reduced from *OA* to some value, *OT*, the load current would change from *OB'* to

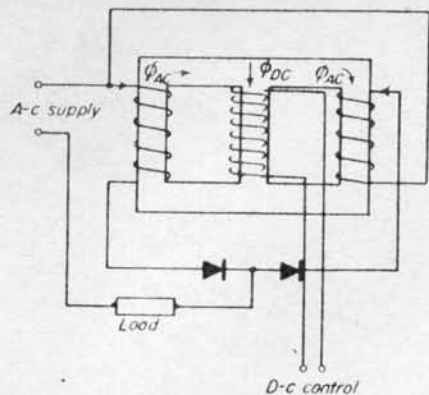

Fig. 3—Doubler circuit giving a-c output. Only second harmonic and higher-order even-harmonic voltages are induced in the d-c winding by transformer action.

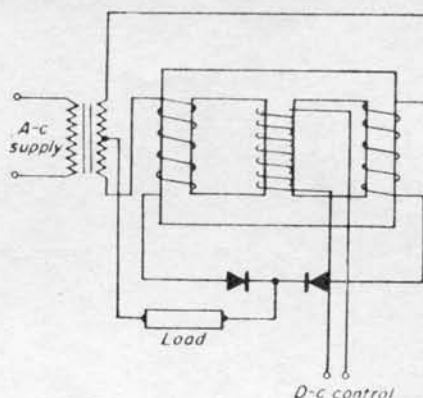

Fig. 4—Magnetic amplifier circuit similar to a full-wave electronic rectifier circuit. Output is d-c, instead of a-c as in the previous circuit.

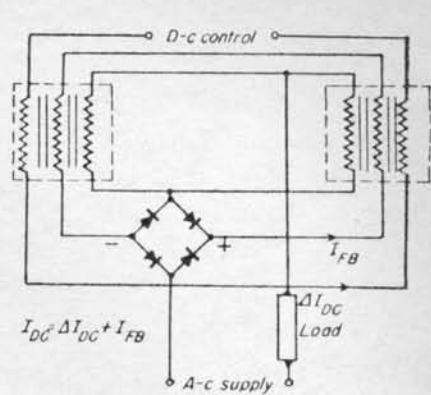

Fig. 5—Amplification factor of a magnetic amplifier can be increased by use of a feedback circuit. Saturation current is equal to the quantity shown.

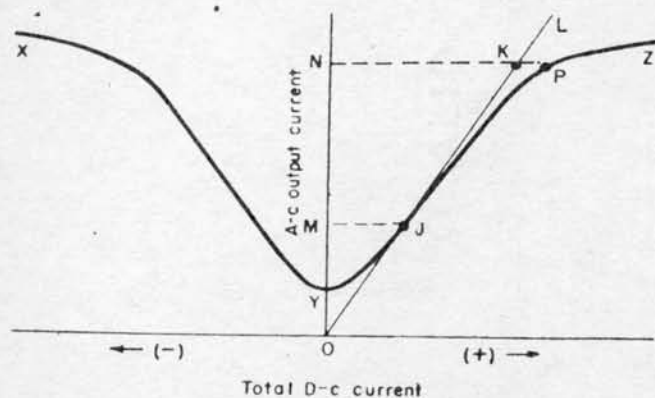

Fig. 6—How feedback increases amplification factor. If XYZ represents a plot of a-c output current vs. d-c signal current and OL is a plot of the feedback current, J is the operating point. An increase in signal current KP increases output OM to ON.

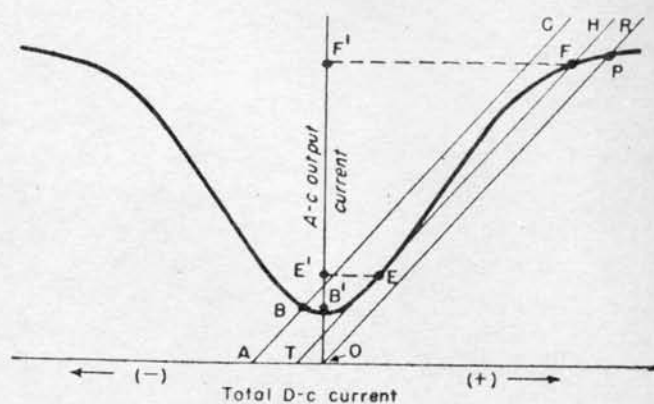

Fig. 7—Excessive positive feedback decreases the linearity of the output-control current curve. It gives a "snap action" when the signal current is decreased from OA to OT, since the output current jumps first from OB' to OE' and then quickly to OF'.

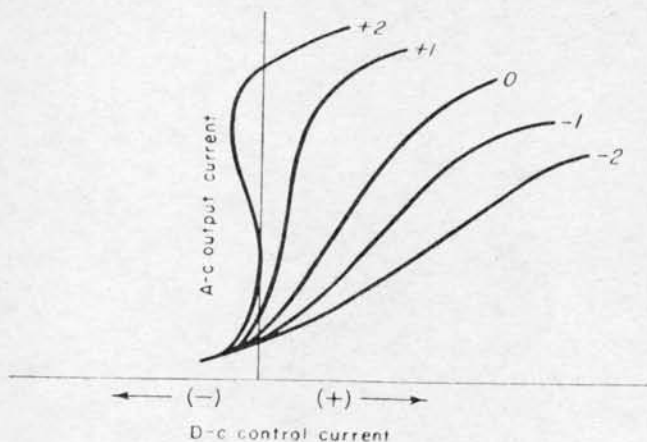

Fig. 8—Effect of negative and positive feedback on the characteristic curves of magnetic amplifiers. Negative feedback increases the linearity. "Plus" curves indicate positive feedback.

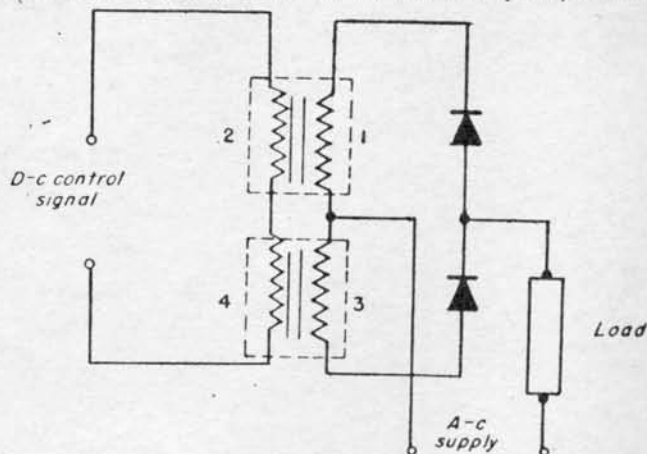

Fig. 9—Magnetic amplifier in which both the d-c feedback current and the a-c supply current flow in a common winding. Advantage of this circuit, is little complexity and low cost.

OE', then jump quickly to OF'. This "snap" action gives a characteristic similar to the curve labeled "+2" in Fig. 8. A magnetic amplifier designed with the proper amount of self-excitation to give "snap" action might be used effectively to operate a relay.

If the self-excitation windings are

connected so as to decrease core saturation, the feedback is negative. Negative feedback improves the linearity of the characteristic curves, as seen in Fig. 8 (Curves labeled "-1" and "-2".)

Thus far in the discussion of self-excitation for magnetic amplifiers it

has been assumed that the feedback was applied to an isolated set of windings such as those in Fig. 3. A scheme wherein both the d-c feedback current and the a-c power current flow in a common winding is shown in Fig. 9. In this circuit, d-c current flows in the loop composed of coils 1 and 3

and the two rectifiers. The output voltage across the load would be an a-c voltage, but, if desired, a second rectifier bridge could be added to give d-c output voltage.

In many applications of amplifiers, it is undesirable to have a static output current when the input d-c current is zero. The schematic in Fig. 10 has been included in this paper because it represents one type of circuit that has been corrected for "zero signal." Reference to the diagram will show that reactor windings *B* and *C* will take a small exciting current from the transformer *T*, even though the signal current in *A* is zero. This exciting current will be rectified by *L*, and although it will have only a small magnitude, it will appear as a d-c signal in control winding *E* of the second stage. Reactor windings *F* and *G* will also take a small exciting current from transformer *T*. In addition, they will take an increase in current because of the false signal in *E*. Unless compensation were employed, this total a-c current would be rectified by *M* and would appear as a steady d-c current through the operating winding *W* on the relay, even though the input current through *A* were zero. The circuit of Fig. 10 has been corrected for zero signal by the addition of rectifier *N* and compensating windings *H* and *S*. D-c cur-

rent of sufficient magnitude and correct polarity is fed back from *N* through *H*, to cancel the effect of the false signal in *E*. In a like manner, d-c current is circulated through winding *S* to nullify the effect of the normal exciting current through *F* and *G*, rectified by *M*, and circulated through operating winding *W*. Thus, by proper adjustment of the two resistors *R*, the inherent effects of exciting current can be completely nullified, and the pull on the relay armature is zero when the input signal is zero. The circuit shown uses only two amplifier stages. However, more stages could be employed and properly corrected for zero signal by a similar scheme.

The schematic diagram in Fig. 11 shows how the frequency of a 400-cycle alternator, driven by a separately excited d-c motor, can be stabilized by a magnetic-amplifier control. The saturable reactor winding *W* is linked magnetically with windings *X*, *Y*, and *Z*. Winding *Z* is essentially a feedback winding. The relative polarity of d-c ampere turns is such that an increase of current in windings *Y* and *Z* increases the a-c current in winding *W*, but an increase of current in *X* decreases the a-c current in *W*. Rectifier *F* supplies shunt-field current to the d-c motor. A-c current to rectifier *R* passes through a

series-tuned circuit *L*, resonant at 350 cps. The filter circuit *M* supplying rectifier *S* is resonant at 450 cps. The principle of operation is as follows: Assume that alternator frequency is 400 cps. Reference to the filter-characteristic curves shows that the two series filters *L* and *M* are drawing equal currents. Therefore, currents in windings *X* and *Y* are having no net effect on the saturation of reactor *W*. If the motor speed decreases, the alternator frequency will drop below 400 cps. Filter *L* takes more current; filter *M* takes less current. (Operating points 3 and 1) Under these conditions, the net flux (ϕ_x minus ϕ_y) will decrease core saturation in *W*. Then less field current will be supplied to the motor, its speed will be increased, and the alternator frequency will be increased. Conversely, if alternator frequency is too high, filter operation will be at points 5 and 4, and increased core saturation will increase field current, decrease motor speed and alternator frequency.

In the circuit described above, the effect of "hunting" has been neglected. Furthermore, in practical applications, it would be desirable to furnish a regulated voltage to rectifier *F*. This would prevent the control circuit from misinterpreting a low-voltage condition as a low-frequency condition.

Fig. 10—Two-stage manetic amplifier circuit corrected for zero signal input which is necessary when the amplifier is connected to a relay so that the pull on the relay is zero with zero input.

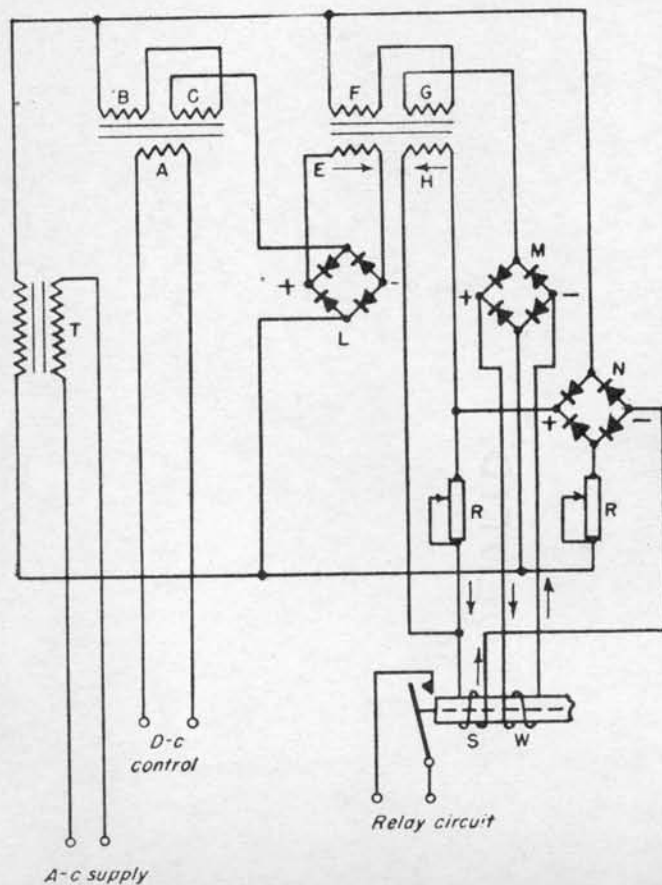

Fig. 11—Magnetic amplifier circuit for stabilizing the frequency of a 400 cycle alternator driven by a separately excited d-c motor. In this circuit, the effect of hunting has been neglected.

